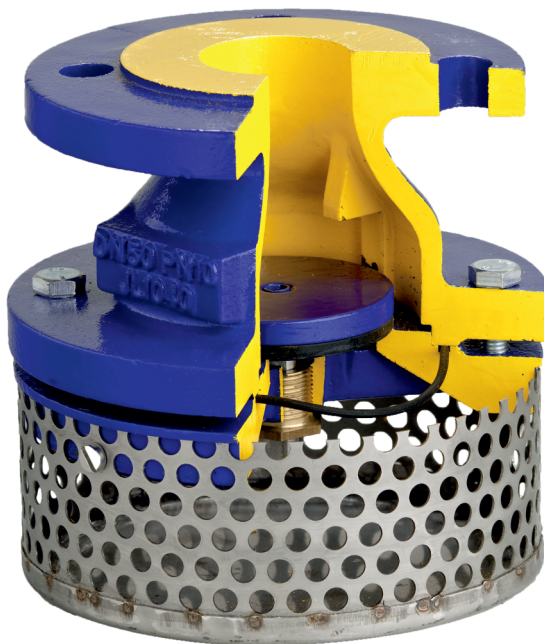



figure	935
ends form	flange straight

## BOTTOM VALVE zBOT

body material	nominal pressure	nominal diameter	max. temperature
A grey cast iron	B 10 bar	DN 40-300	90°C



### FEATURES

- high tightness (leakproofness class - A acc. to EN -12266 - 1)
- compact settlement
- environment-friendly
- no maintenance
- flanges drilled acc. to EN 1092-2

### APPLICATION

- industrial water
- neutral fluids

Data given can be changed without notice.

Edition 06/2016



**figure 935**  
 ends form flange straight

**MATERIALS**

type 06

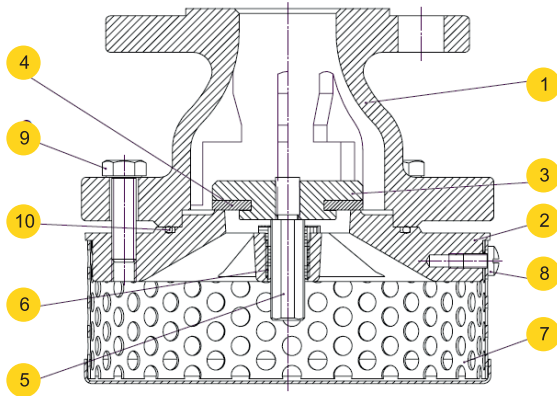

type 00

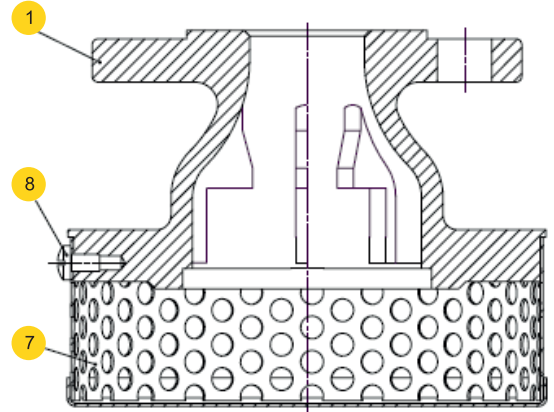

body material		A	
type		06	00
1	body	EN – GJL-250 JL1040	
2	cover	EN – GJL-250 JL1040	----
3	disc	EN – GJL-250 JL1040	----
4	disc gasket	EPDM	----
5	stem	X20Cr13 1.4021	----
6	sleeve	CuZn40Pb2	----
7	screen	X5CrNi18-10 1.4301	
8	screw	A2-70	
9	hexagon bolt	8.8 - A2A	----
10	packing ring	EPDM	----
max. temperature		90°C	

Data given can be changed without notice.

Edition 06/2016



**figure 935**  
ends form flange straight

**DIMENSIONS**

type 00

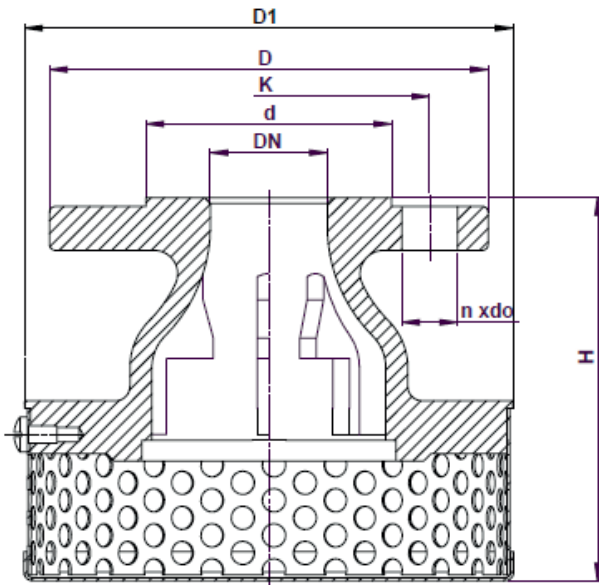

type 06

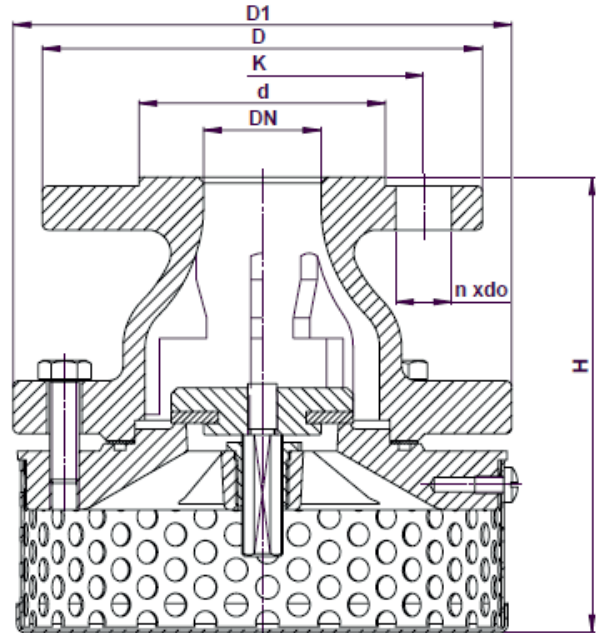

DN	PN 10 (typ 00, 06)						PN 10 (typ 06)			PN 10 (typ 00)		
	D1	D	K	d	do	n	H	Kvs		H	Kvs	
mm							mm	m <sup>3</sup> /h	kg	mm	m <sup>3</sup> /h	kg
40	170	150	110	84	19	4	155	37,8	8,5	132	61,5	5,0
50	180	165	125	99	19	4	175	47,0	9,5	152	96,7	6,0
65	200	185	145	118	19	4	215	55,1	12,5	192	164,3	8,0
80	240	200	160	132	19	8	265	149,4	18,0	240	249,6	11,0
100	270	220	180	156	19	8	315	236,5	26,0	290	388,3	15,0
125	310	250	210	184	19	8	335	359,1	32,0	310	606,0	21,0
150	360	285	240	211	23	8	415	501,0	43,0	390	870,1	29,0
200	440	340	295	266	23	8	500	858,2	74,0	470	1551,9	45,0
250	520	395	350	319	23	12	625	1349,3	107,0	595	2431,1	74,0
300	570	445	400	370	23	12	785	1887,6	150,0	755	3502,8	88,0

Data given can be changed without notice.

Edition 06/2016



figure	935
ends form	flange straight

## PRESSURE-TEMPERATURE RATINGS

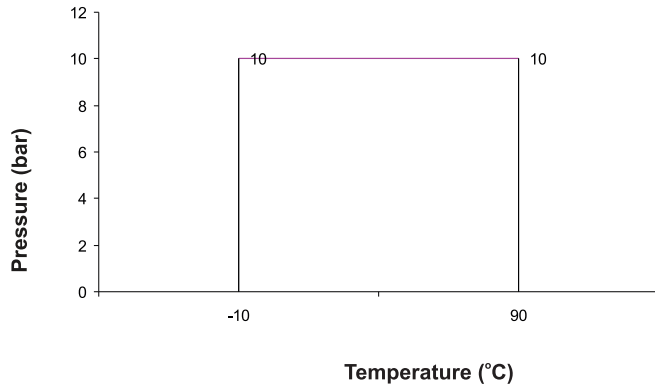

Allowed working conditions range  
PN 16 EN-GJL-250



figure	<b>935</b>
ends form	flange straight

## TYPES

figure	body material	nominal diameter DN	nominal pressure PN	type
<b>935</b>	<b>A</b> grey cast iron EN-GJL-250	<b>40-300</b> mm	<b>B</b> 10bar	<b>06</b> Tmax 90 °C * basket - stainless steel - with non-return disc • sealing EPDM/ cast iron
				<b>00</b> Tmax 90 °C * basket - stainless steel - without non-return disc
				<b>06-D</b> Tmax 80 °C * basket - stainless steel - with non-return disc • sealing EPDM/ cast iron - epoxyd painted
				<b>00-D</b> Tmax 80 °C * basket - stainless steel - without non-return disc - epoxyd painted

## ORDERING

To place an order please use our product number (index)

figure	body material	nominal diameter DN	nominal pressure PN	type
<b>935</b>	<b>A</b>	<b>040</b>	<b>B</b>	<b>06</b>

### ORDER EXAMPLE

	935	A	040	B	06
bottom valve, ends threaded, form straight	935				
grey cast iron EN-GJL-250		A			
nominal diameter DN40			040		
nominal pressure PN10				B	
basket stainless steel • with non-return disc • sealing EPDM/ cast iron					06