



figure 302

ends form flanged straight



## CHECK VALVE zCHE

body material	nominal pressure	nominal diameter	max. temperature
A grey cast iron	C 16 bar	DN 40-300	300°C
	B 10 bar	DN 40-250	

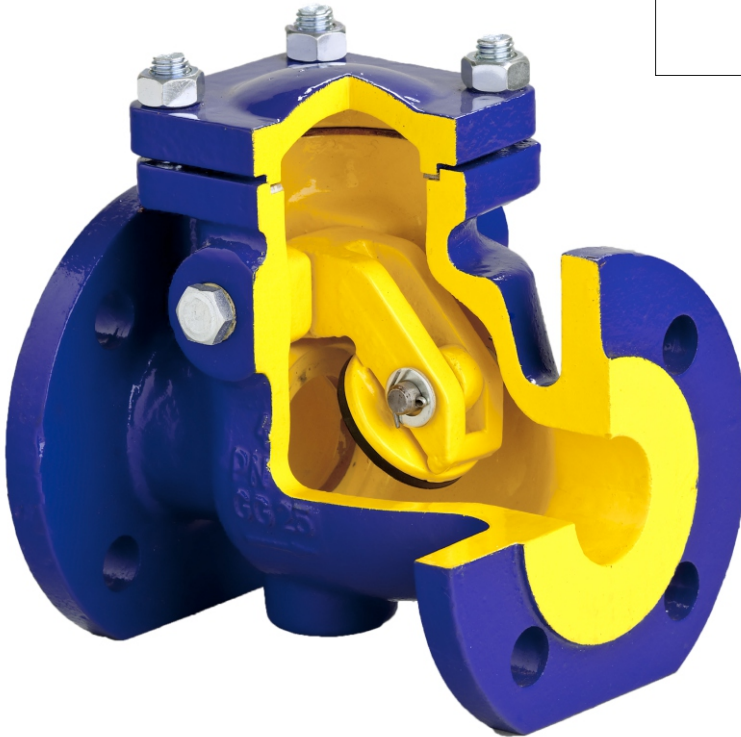

correspond to the pressure equipment directive 2014/68/UE

### FEATURES

- closing tightness acc. to EN -12334
- compact settlement
- environment-friendly
- no maintenance
- flanges drilled according to EN 1092-2
- face-to-face dimension according to EN 558 series 48

### APPLICATION

- hot and cold water plants
- steam plants
- industrial technologies
- neutral fluids
- heat and refrigerating engineering,

Data given can be changed without notice.

Edition 06/2016



figure

302

ends  
form

flanged  
straight

## MATERIALS

type 01; 02

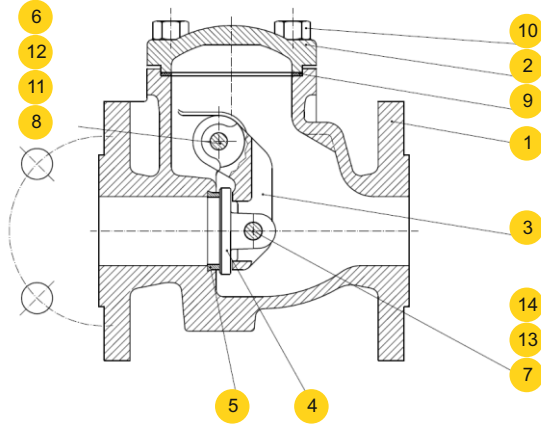

type 06

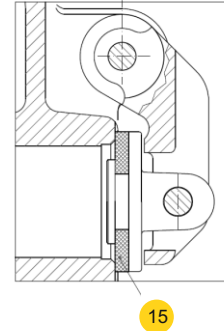

type 91

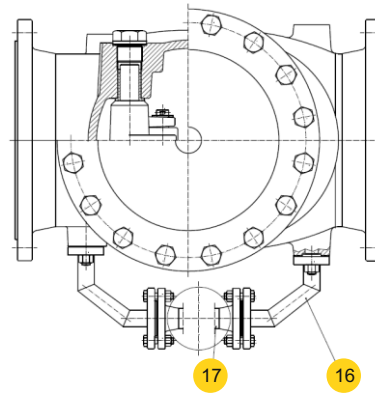

body material		A			
type		01	02	06	91
1	body	EN – GJL-250 5.1301 (ex.JL1040)			
2	cover	EN – GJL-250 5.1301 (ex.JL1040)			
3	hinge	EN – GJS-500-7 5.3200(ex.JS1050)			
4	flap	LH14 (G-X20Cr14)	G-CuSn10-B	EN – GJS-500-7 5.3200(ex.JS1050)	LH14 (G-X20Cr14)
5	seat ring	X12Cr13 1.4006	G-CuSn10-B	-	X12Cr13 1.4006
6	pin bearing	brass for DN 200-300			
7	flap pin	X20Cr13 1.4021	CuZn40Pb2	X20Cr13 1.4021	X20Cr13 1.4021
8	pin	X20Cr13 1.4021	CuZn40Pb2	X20Cr13 1.4021	X20Cr13 1.4021
9	cover gasket	graphite CrNi			
10	bolt	8.8 A2A			
11	plug	10S20 zinc galvanized for DN 40-150 EN-GJL-250 JL1040 for DN 200-300			EN-GJL-250 JL1040
12	plug gasket	carbomide-rubber			
13	washer	carbon steel A2A			
14	split pin	X5CrNi18-10			
15	disc gasket	-	-	EPDM	-
16	pipeline	-	-	-	carbon steel
17	by-pass	-	-	-	Fig. 215
max. temperature		300°C	225°C	120°C	300°C

Data given can be changed without notice.

Edition 06/2016



figure

302

ends  
form

flanged  
straight

## MATERIALS

type 11; 21;12;22

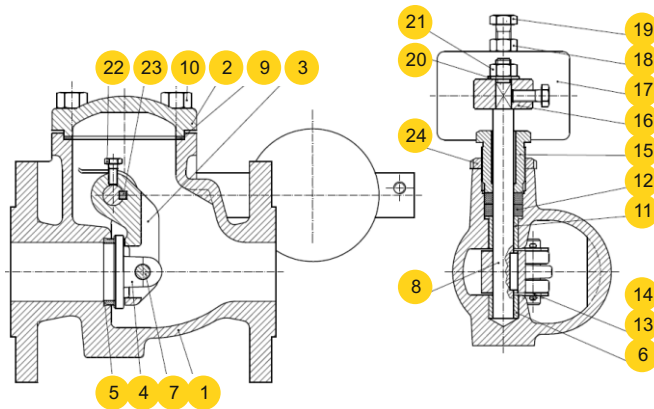

type 16; 26

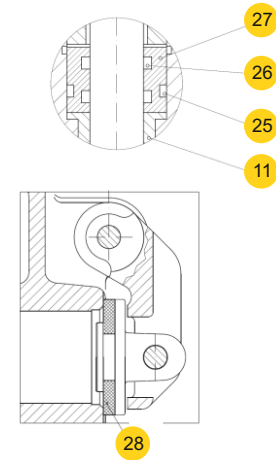

body material		A		
type		11; 21	12; 22	16; 26
1	body		EN – GJL-250 5.1301 (ex.JL1040)	
2	cover		EN – GJL-250 5.1301 (ex.JL1040)	
3	bow		EN – GJS-500-7 5.3200(ex.JS1050)	
4	flap	LH14 (G-X20Cr14)	G-CuSn10-B	EN – GJS-500-7 5.3200(ex.JS1050)
5	seat ring	X12Cr13 1.4006	G-CuSn10-B	-
6	bearing sleeve		brass for DN 200-300	
7	flap pin	X20Cr13 1.4021	CuZn40Pb2	X20Cr13 1.4021
8	shaft	X20Cr13 1.4021	CuZn40Pb2	X20Cr13 1.4021
9	cover gasket		graphite CrNi	
10	bolt		8.8 A2A	
11	neck bush		MM58 (CuZn40Mn1,5)	
12	packing.		graphite	-
13	washer		carbon steel A2A	
14	split pin		X5CrNi18-10	
15	gland		EN – GJL-250 5.1301 (ex.JL1040)	
16	hinge		S235JR	
17	weight		EN – GJL-250 5.1301 (ex.JL1040)	
18	nut		8.8 A2A	
19	bolt		33H-A2A	
20	washer		carbon steel A2A	
21	nut		8.8 A2A	
22	bolt		33H-A2A	
23	sunk key		X20Cr13 1.4021	
24	nut		KM-6A2A	
25	seat ring	-	-	EPDM
26	seat ring	-	-	EPDM
27	pilot sleeve	-	-	M63
28	disc gasket	-	-	EPDM
max. temperature		300°C	225°C	120°C

Data given can be changed without notice.

Edition 06/2016



figure

302

ends  
form

flanged  
straight

## MATERIALS

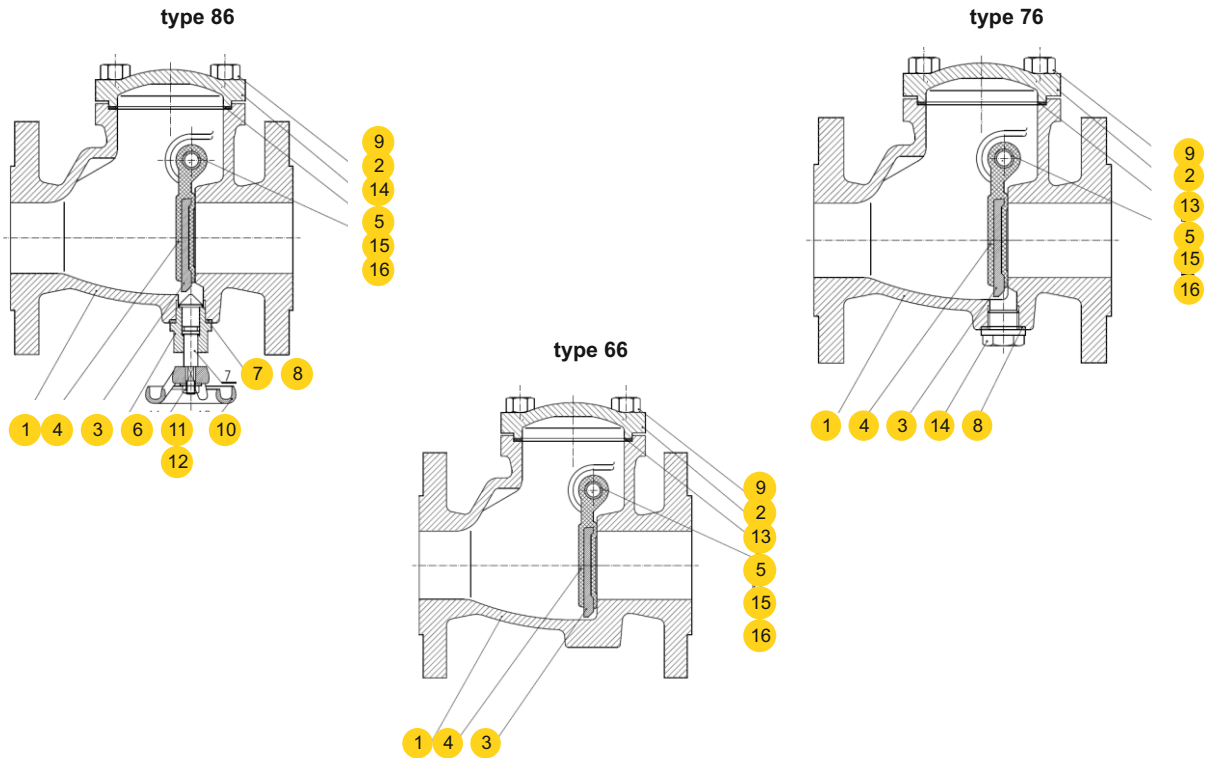

body material		A		
type		86	76	66
1	body	EN – GJL-250 5.1301 (ex.JL1040)		
2	covert	EN – GJL-250 5.1301 (ex.JL1040)		
3	flap	EN – GJS-500-7 5.3200(ex.JS1050)		
4	flap gasket	EPDM		
5	pin	X20Cr13 1.4021		
6	sleeve	CuZn40Mn1.5	-	-
7	stem	CuZn40Mn1.5	-	-
8	gasket	carbomide-rubber		-
9	bolt	8.8 A2A		
10	hand wheel	EN – GJL-250 5.1301 (ex.JL1040)	-	-
11	nut	8.8 A2A	-	-
12	washer	carbon steel A2A	-	-
13	cover gasket	graphite CrNi		
14	plug	-	CuZn37	-
15	plug	10S20 zinc		
16	plug gasket	carbomide-rubber		
max. temperature		120°C		

Data given can be changed without notice.

Edition 06/2016



## DIMENSIONS

type 01; 02; 06

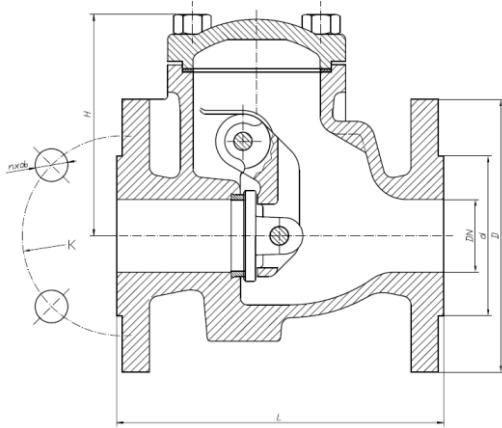

type 86

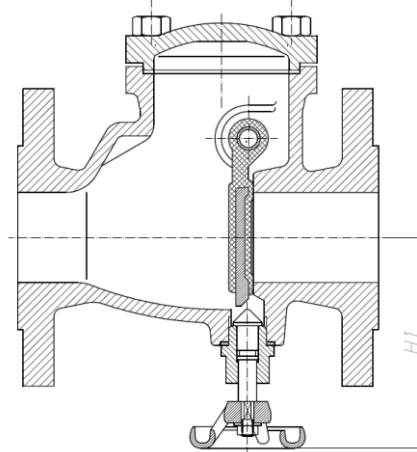

type 11; 12; 16; 21; 22; 26

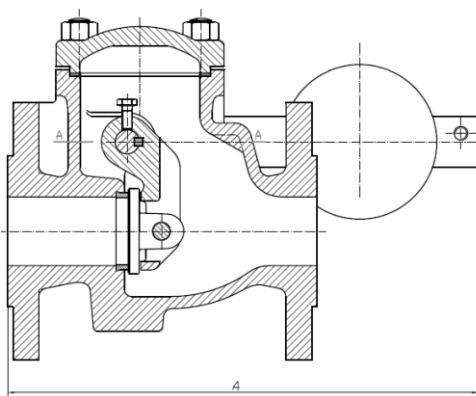

type 91

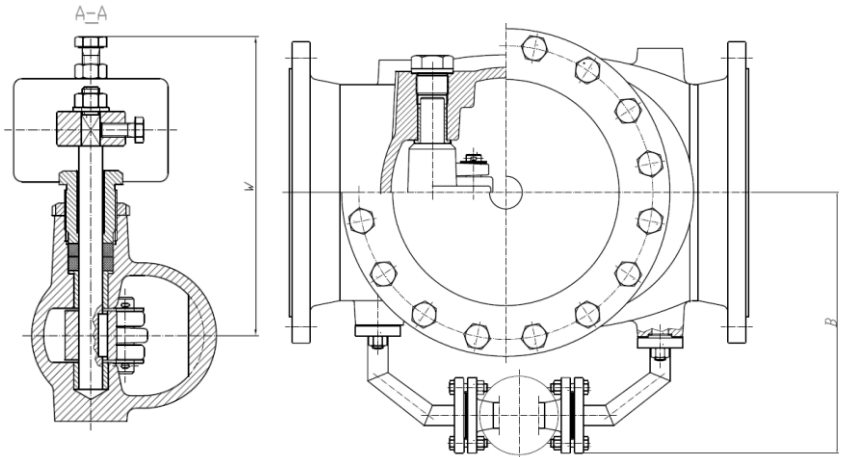

DN	302						302.21,22,26	302.86	302.91	302.01 302.02		302.11,21 302.12,22		302.86	302.91	Kvs
	L	D	d	K	nxdo	H	A	W	H1	B	▲ ▲					
mm											kg				m <sup>3</sup> /h	
40	180	150	84	110	4x19	119	350	170	120	-	9,0	11,8	9,0	-	46,2	
50	200	165	99	125	4x19	120	352	180	125	-	11,0	13,5	12,6	-	78,2	
65	240	185	118	145	4x19	141	359	190	130	-	15,2	18,0	17,0	-	139,1	
80	260	200	132	160	8x19	168	371	200	140	-	20,8	23,5	21,9	-	207,5	
100	300	220	156	180	8x19	175	447	210	175	-	31,5	36,0	31,0	-	336,8	
125	350	250	184	210	8x19	199	466	225	190	-	46,0	51,0	45,0	-	526,3	
150	400	285	211	240	8x23	217	574	250	210	-	60,0	67,0	61,0	-	756,7	
200	500	340	266	295	12x23	292	662	306	280	380	120	129	120	131	1278,0	
250	600	405	319	355	12x28	355	800	348	315	410	180	198	180	202	1996,2	
300	700	460	370	410	12x28	374	820	348	-	400	250	285	-	283	2419,6	

Data given can be changed without notice.

Edition 06/2016



figure **302**

ends form flanged straight

## PRESSURE-TEMPERATURE RATINGS

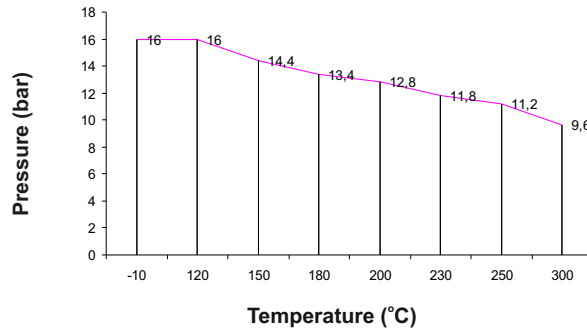

Allowed working conditions range  
PN 16 EN-GJL-250



**figure 302**  
ends form flanged straight

**TYPES**

figure	body material	nominal diameter DN	nominal pressure PN	type
302	A grey cast iron EN-GJL-250	40-300 mm	C 16bar	01 flap and seat ring - stainless steel Tmax 300 °C
				02 flap and seat ring - bronze Tmax 225 °C
				06 flap - nodular cast iron    flap ring EPDM Tmax 120 °C
		40-150 mm	C 16bar	11 flap and seat ring - stainless steel    counterweight and lever fitted on one side Tmax 300 °C
				12 flap and seat ring - bronze    counterweight and lever fitted on one side Tmax 225 °C
				16 flap - nodular cast iron    flap ring EPDM    counterweight and lever fitted on one side Tmax 120 °C
		200-300 mm	C 16bar	21 flap and seat ring - stainless steel    counterweight and lever fitted on both side Tmax 300 °C
				22 flap and seat ring - bronze    counterweight and lever fitted on both side Tmax 225 °C
				26 flap - nodular cast iron    flap ring EPDM    counterweight and lever fitted on both side Tmax 120 °C
		40-250 mm	B 10bar	66 EPDM covered flap Tmax 120 °C
				76 EPDM covered flap    closing EPDM/cast iron plug Tmax 120 °C
				86 EPDM covered flap    rising pin Tmax 120 °C
		200-300 mm	C 16bar	91 flap and seat ring - stainless steel    by pass Tmax 300 °C



figure **302**  
ends form flanged straight

**TYPES**

figure	body material	nominal diameter DN	nominal pressure PN	type
302	A grey cast iron EN-GJL-250	40-300 mm	C 16bar	01-D Tmax 80 °C flap and seat ring - stainless steel epoxy paint
				06-D Tmax 80 °C flap - nodular cast iron flap ring EPDM epoxy paint
		40-150 mm	C 16bar	11-D Tmax 80 °C flap and seat ring - stainless steel counterweight and lever fitted on one side epoxy paint
				16-D Tmax 80 °C flap - nodular cast iron flap ring EPDM counterweight and lever fitted on one side epoxy paint
		200-300 mm	C 16bar	21-D Tmax 80 °C flap and seat ring - stainless steel counterweight and lever fitted on both side epoxy paint
				26-D Tmax 80 °C flap - nodular cast iron flap ring EPDM counterweight and lever fitted on both side epoxy paint
		40-250 mm	B 10bar	66-D Tmax 80 °C EPDM covered flap epoxy paint
				86-D Tmax 80 °C EPDM covered flap rising pin epoxy paint





figure	<b>302</b>
ends form	flanged straight

## ORDERING

To place an order please use our product number (index)



### ORDER EXAMPLE

