



figure

227

ends
formflanged
straight**CONTROL VALVE zCON**

body material	nominal pressure	nominal diameter	max. temperature
A grey cast iron	C 16 bar	DN 15-80	200°C



correspond to the pressure equipment directive 2014/68/UE marking CE for DN \geq 32

FEATURES

- compact settlement
- environment-friendly
- easy to handle
- precision spindle guide
- flow characteristic - equal percentage
- positioning ratio 50:1
- flanges drilled according to EN 1092-1 for body material F
- face-to-face dimension according to EN 558-1 series 1

APPLICATION

- heating
- refrigeration and air conditioning
- industrial water
- neutral fluids

Data given can be changed without notice.

Edition 06/2016



figure

227

ends
form

flanged
straight

MATERIALS

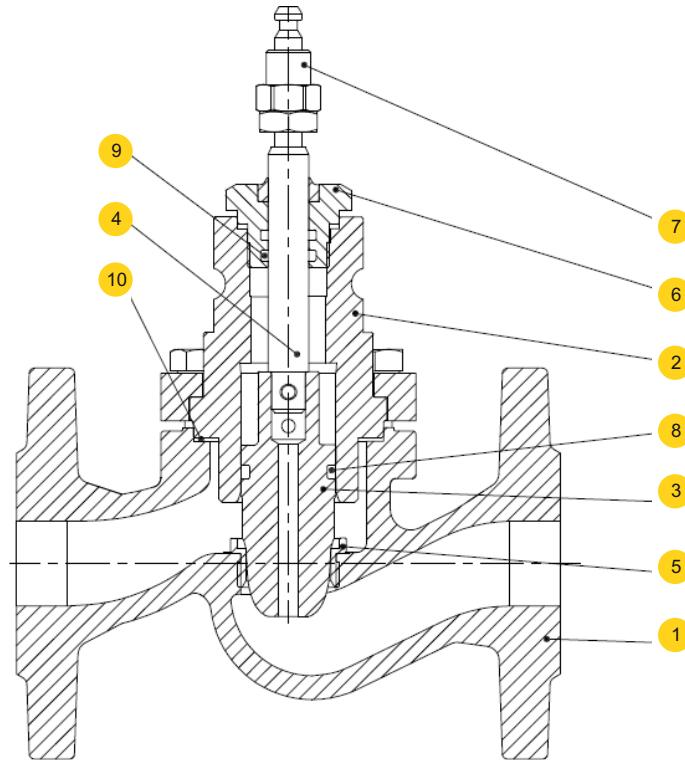

body material		A	
type		80	81
1	body	EN – GJL-250 5.1301 (ex.JL1040)	
2	bonnet	X20Cr13 1.4021	
3	disc	X20Cr13 1.4021	
4	stem	X20Cr13 1.4021	
5	seat ring	X20Cr13 1.4021	
6	bonnet nut	CuZn40Pb2	X20Cr13 1.4021
7	fastener	CuZn40Pb2	
8	disc seat ring	EPDM	Turcon T40
9	stem gasket	EPDM	Turcon T40
10	bonnet gasket	graphite CrNiSt	
11	electric motor	Belimo	
max. temperature		150°C	200°C

Data given can be changed without notice.

Edition 06/2016



figure

227

ends
formflanged
straight

DIMENSIONS

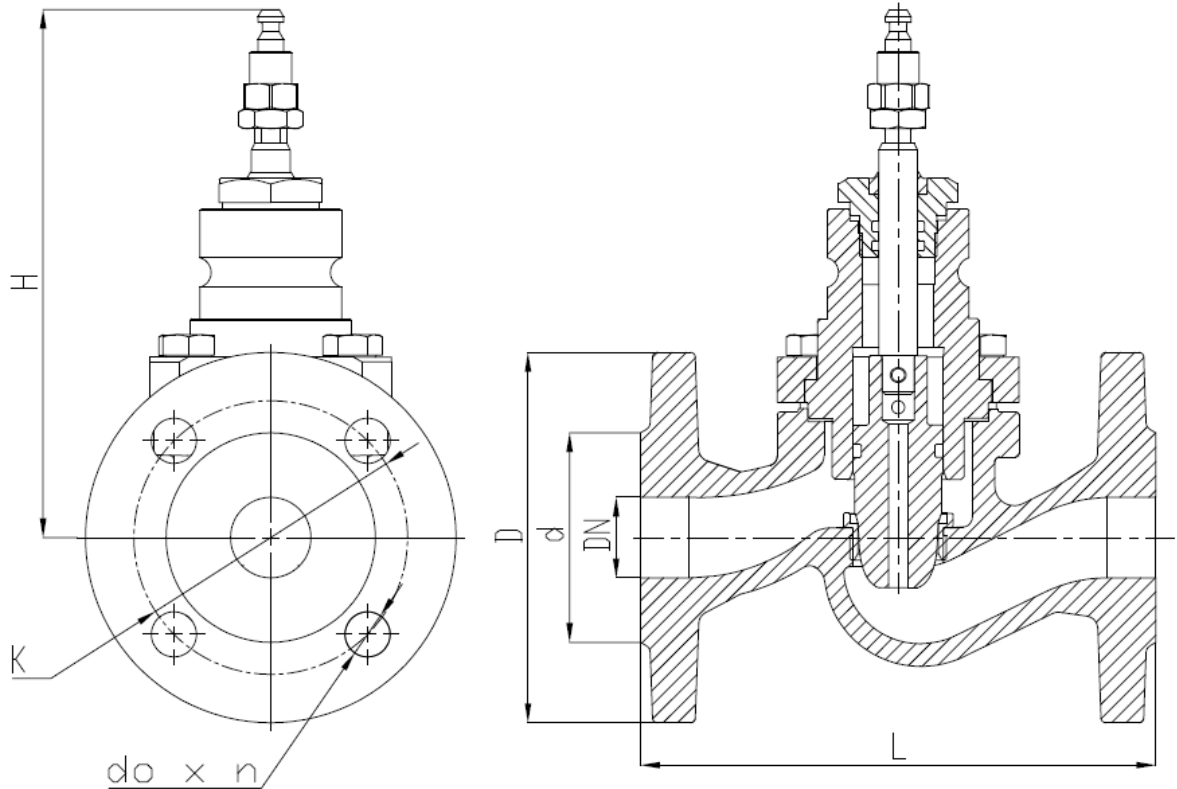

DN	D	d	K	L	H	do x n	Kvs	
mm							m ³ /h	kg
15	95	46	65	130	158	4x14	4,0	4,3
20	105	56	75	150	161	4x14	6,3	4,9
25	115	65	85	160	164	4x14	10,0	5,8
32	140	76	100	180	173	4x19	16,0	7,6
40	150	84	110	200	182	4x19	25	11,0
50	165	99	125	230	190	4x19	40	13,2
65	185	118	145	290	212	4x19	63	18,3
80	200	132	160	310	224	8x19	100	24,6

Data given can be changed without notice.

Edition 06/2016



figure

227

ends
form

flanged
straight

PRESSURE-TEMPERATURE RATINGS

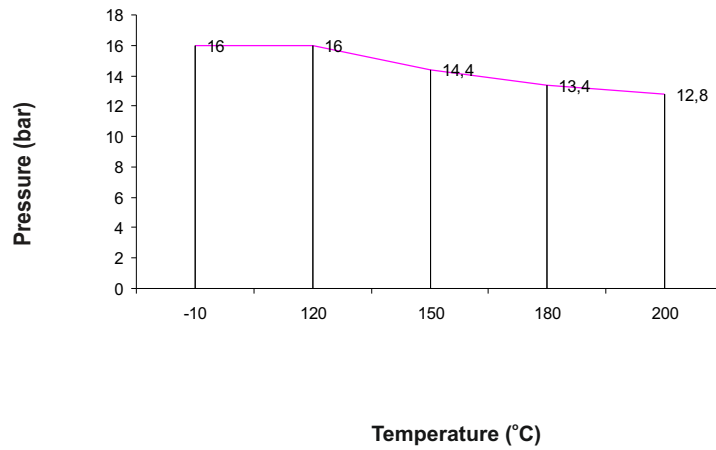

Allowed working conditions range
PN 16 EN-GJL-250



figure

227

ends
formflanged
straight

ELECTRIC MOTOR

technical data of electric motor BELIMO NV24-3 (NV 230-3)

motor voltage	24C; 220V; F=50...60Hz
nominal force	800N
time	150s
travel	20 mm+1mm
power input	3W (6W)
protection	IP 54
ambient temperature	0...+50 °C
manual adjustment	tak/ <i>yes</i>
weight	1,5 kg

REGADA ACTUATOR ON-OFF TYP ST 0 490.0-0HEAX/00

technical data of actuator

motor voltage	230 V AC
nominal force	1600N
switching speed	20mm/min
travel	20 mm+1mm
power input	2.75 W
protection	IP 54
ambient temperature	0...+55 °C
manual adjustment	Yes

REGADA ACTUATOR TYP ST 0PA 430.1-0HJGX/AD

technical data of actuator

motor voltage	230 V AC
nominal force	1280N
switching speed	20mm/min
travel	10-28 mm programmable
power input	3 W
protection	IP 67
ambient temperature	0...+55 °C
manual adjustment	yes
adjustment	-signal 4-20 mA -Sygnał odwzorowania 4-20 ma - passive

Data given can be changed without notice.

Edition 06/2016



figure

227

ends
form

flanged
straight

HYDRAULIC CHARACTERISTICS DN 15

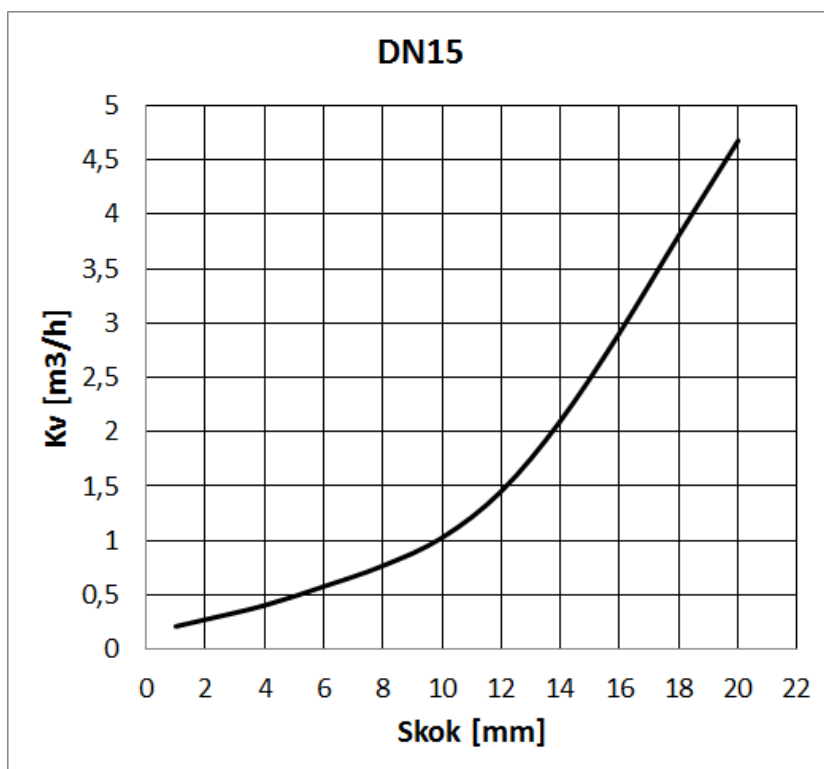
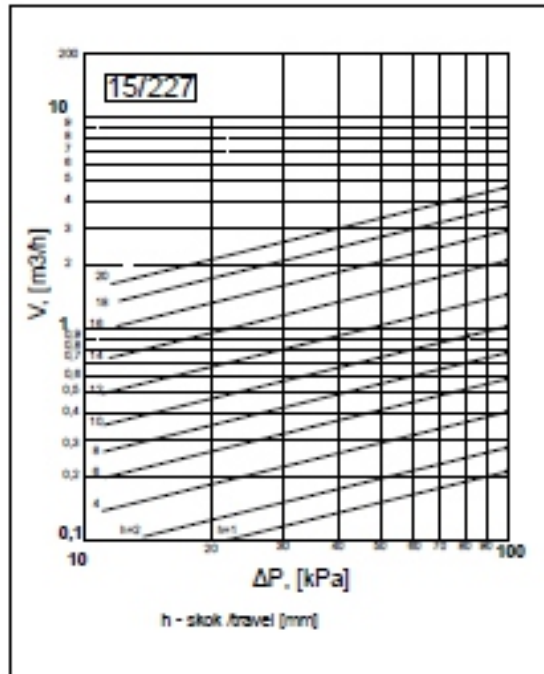



figure

227

ends
form

flanged
straight

HYDRAULIC CHARACTERISTICS DN 20

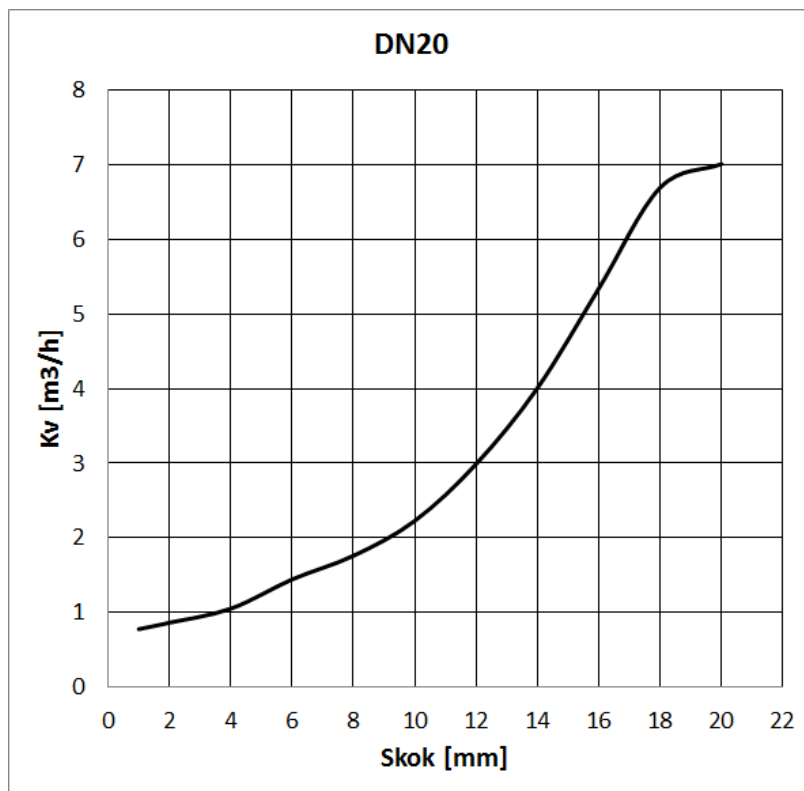
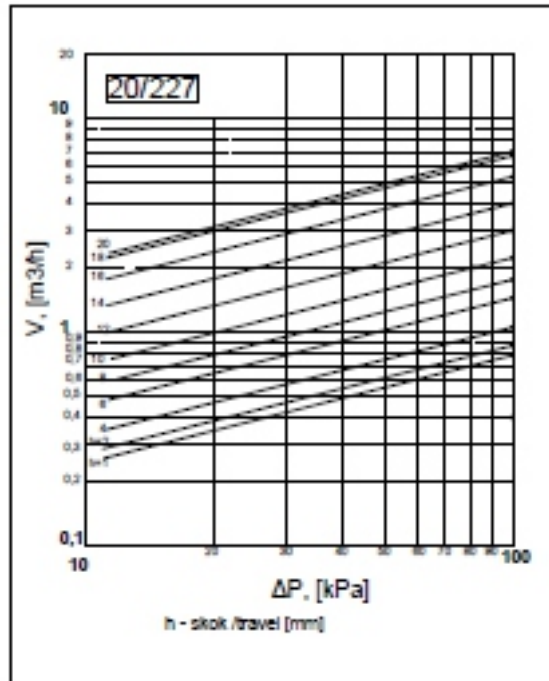

Data given can be changed without notice.

Edition 06/2016



figure

227

ends
form

flanged
straight

HYDRAULIC CHARACTERISTICS DN 25

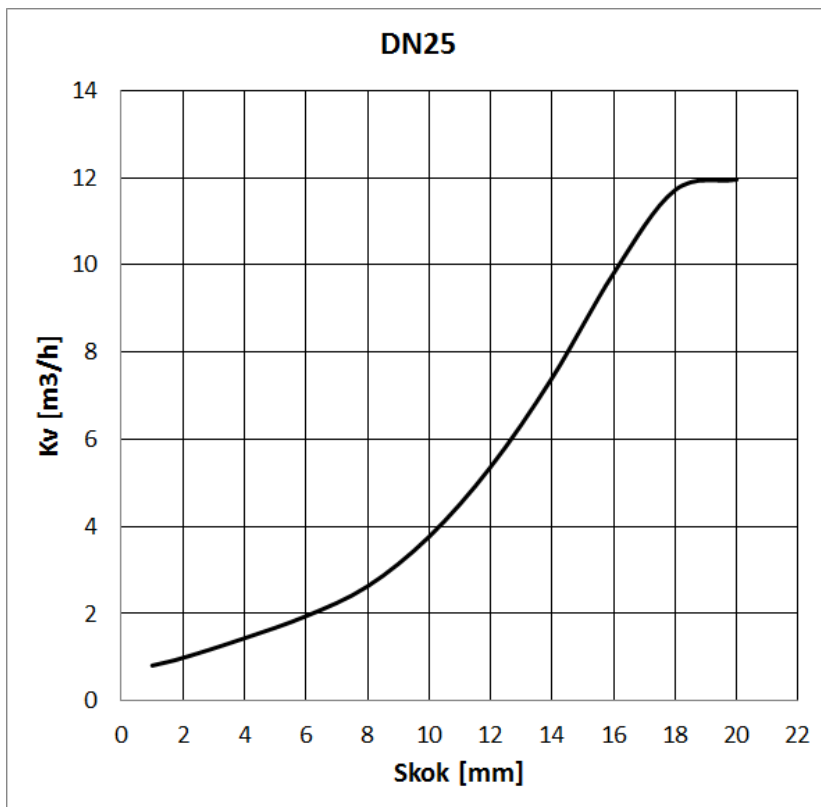
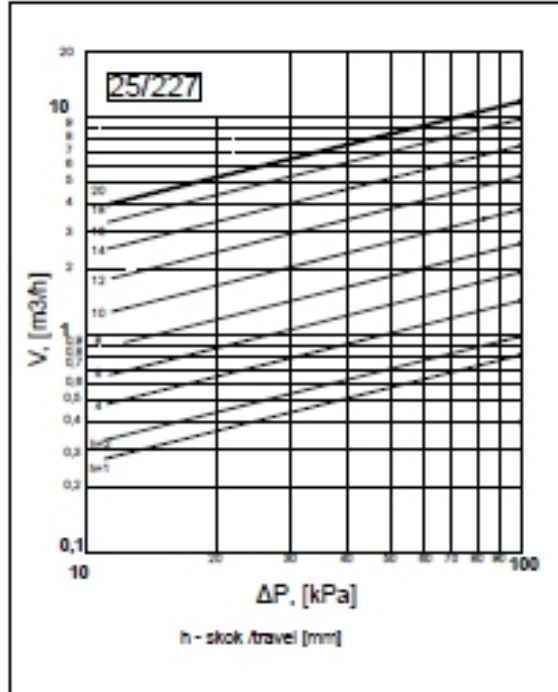

Data given can be changed without notice.

Edition 06/2016



figure

227

ends
form

flanged
straight

HYDRAULIC CHARACTERISTICS DN 32

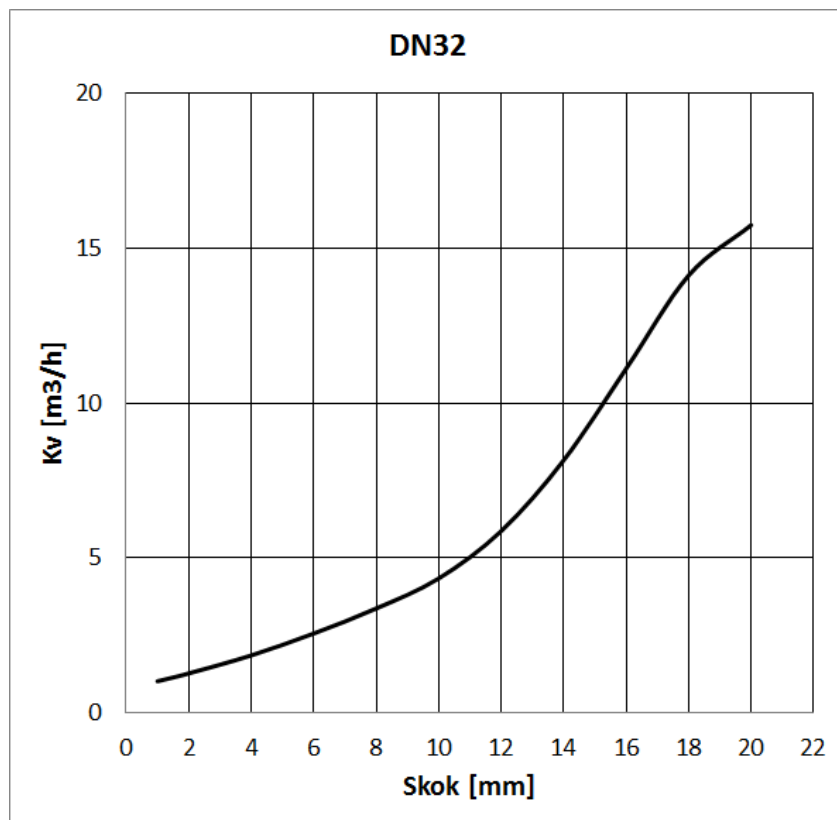
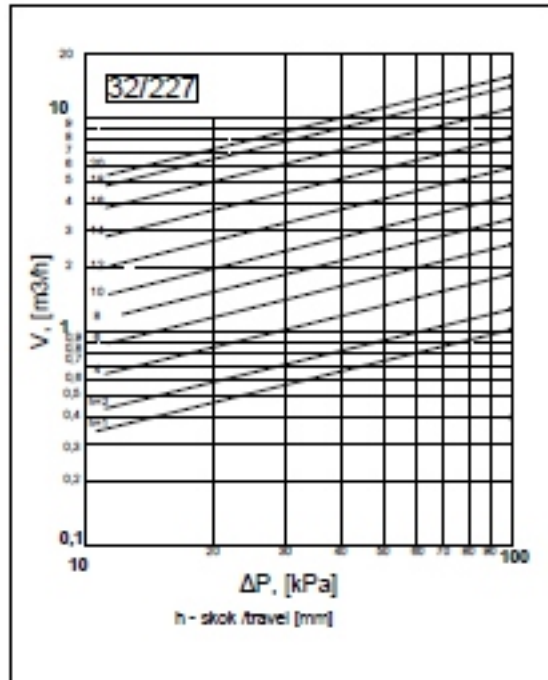

Data given can be changed without notice.

Edition 06/2016



figure **227**
ends flanged
form straight

HYDRAULIC CHARACTERISTICS DN 40

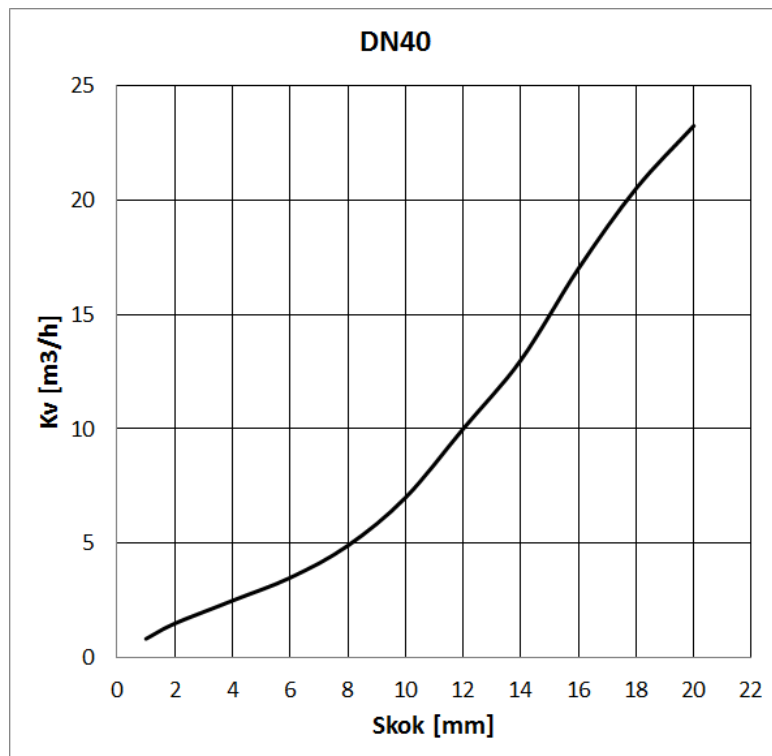
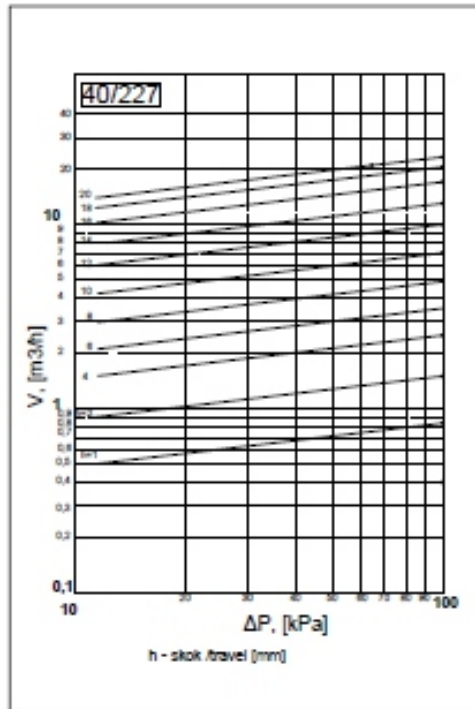

Data given can be changed without notice.

Edition 06/2016



figure

227

ends
form

flanged
straight

HYDRAULIC CHARACTERISTICS DN 50

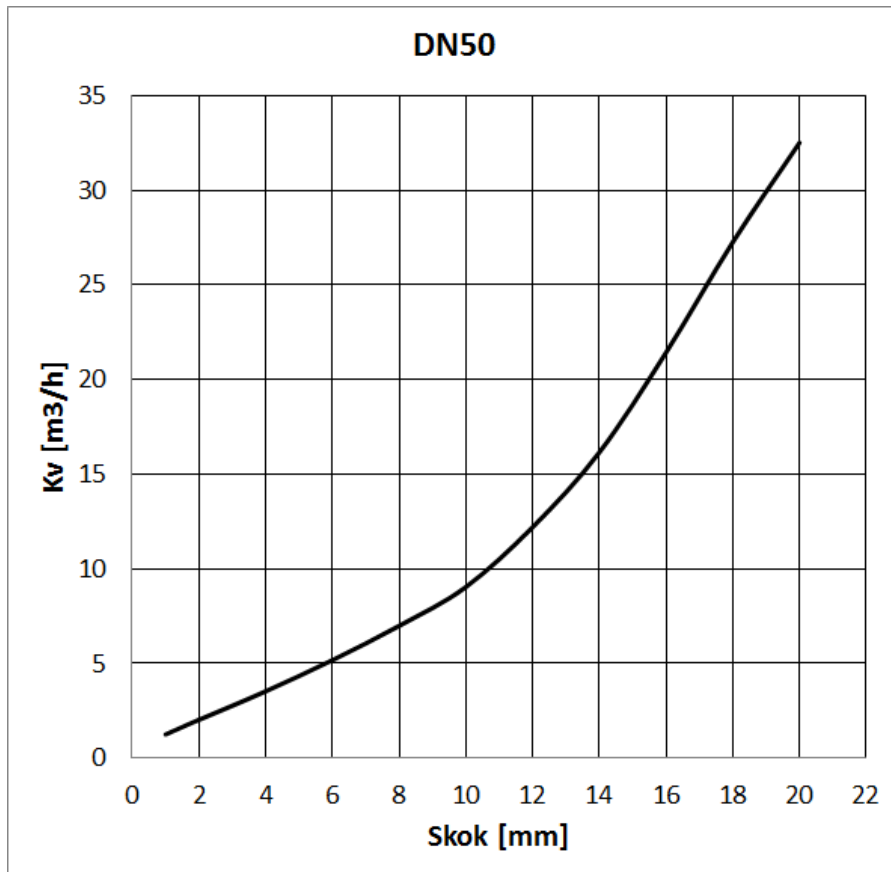
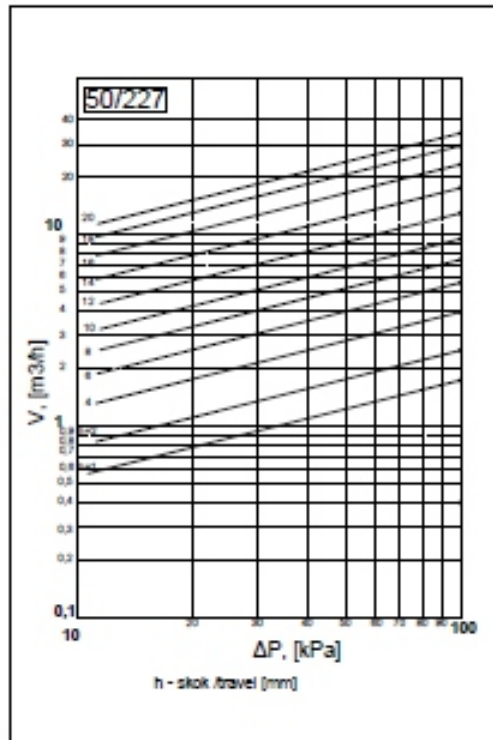

Data given can be changed without notice.

Edition 06/2016



figure

227

ends
form

flanged
straight

HYDRAULIC CHARACTERISTICS DN 65

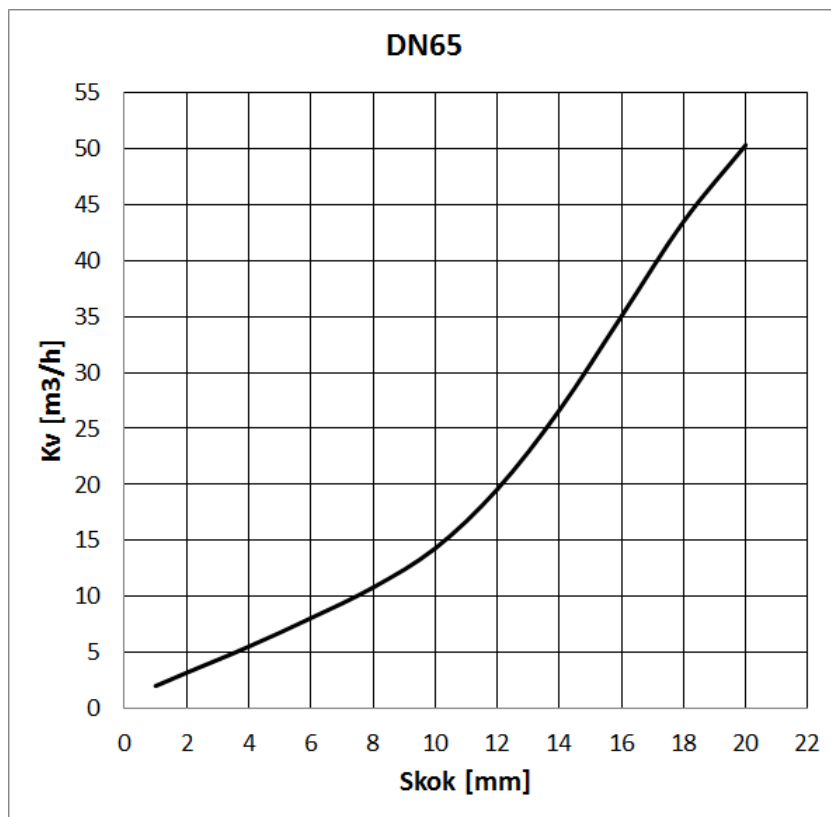
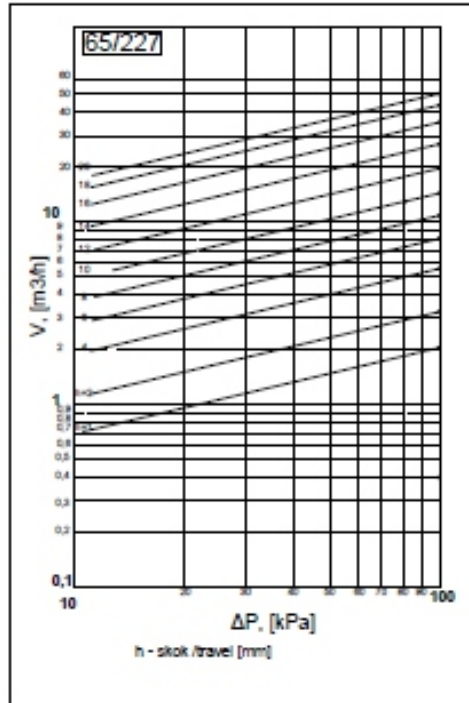

Data given can be changed without notice.

Edition 06/2016



figure

227

ends
form

flanged
straight



ZETKAMA

HYDRAULIC CHARACTERISTICS DN 80

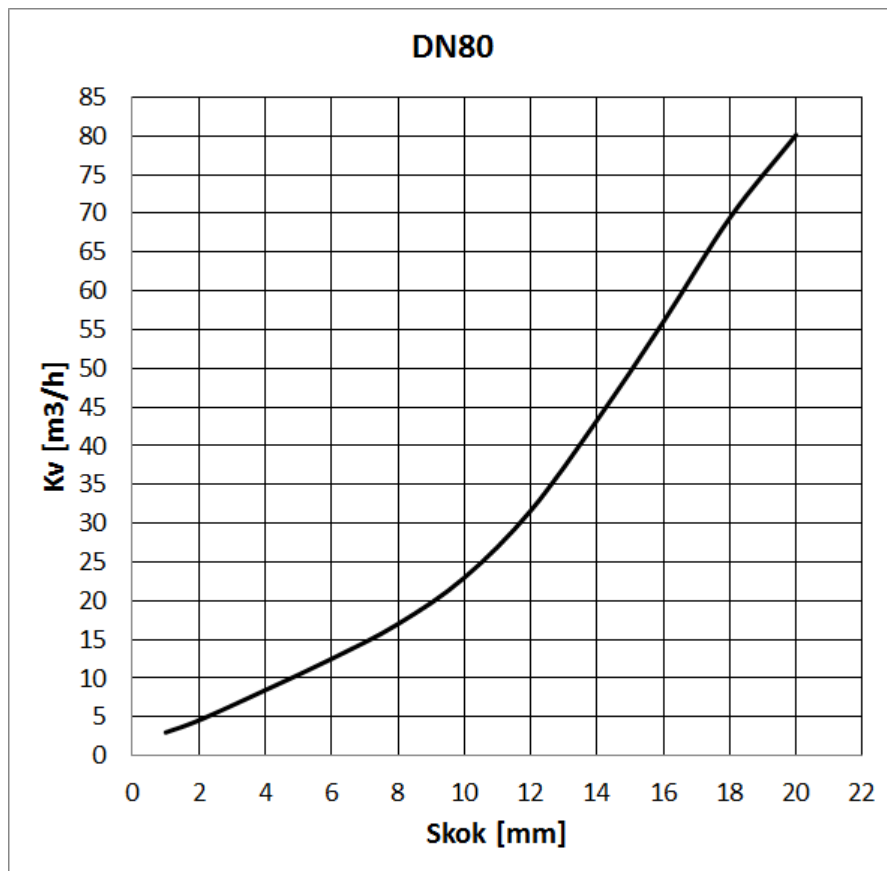
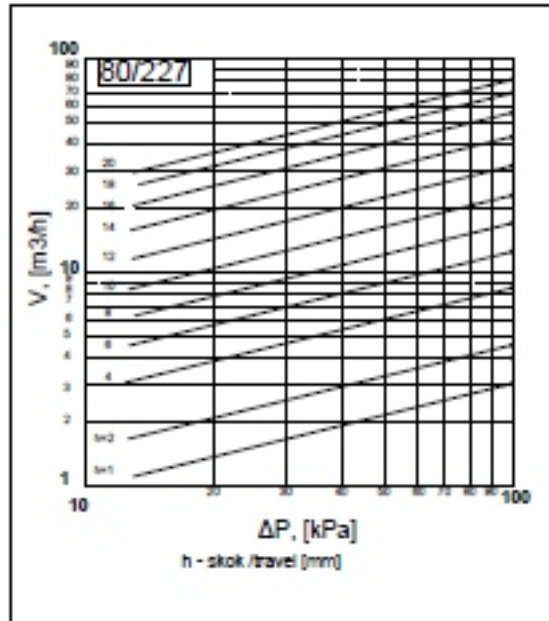

Data given can be changed without notice.

Edition 06/2016



figure	227
ends form	flanged straight

TYPES

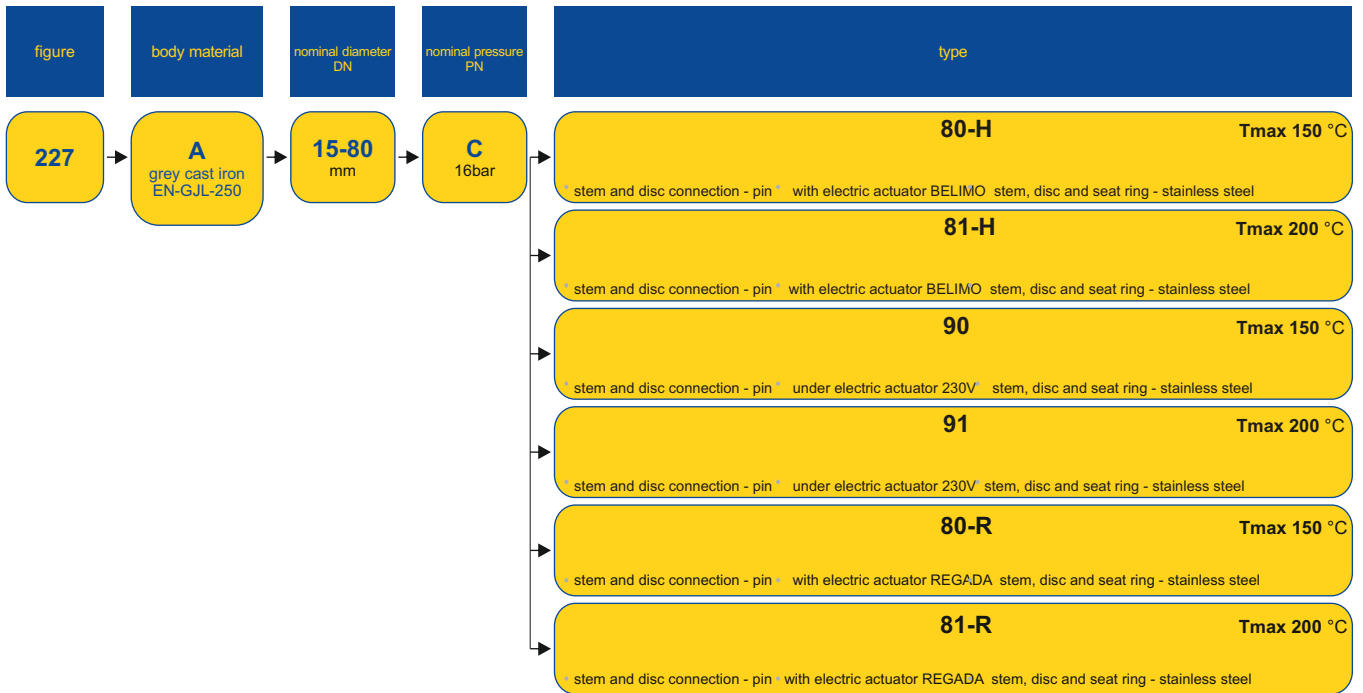

ORDERING

To place an order please use our product number (index)



ORDER EXAMPLE

